

CAD FILE:

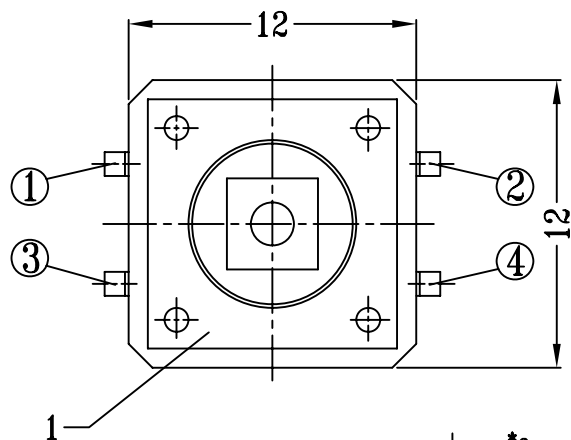

OPERATING FORCE	CODE
160gf	X
250gf	Z

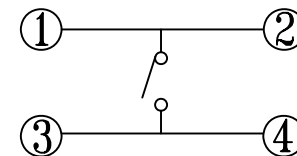

**SCHEMATIC**

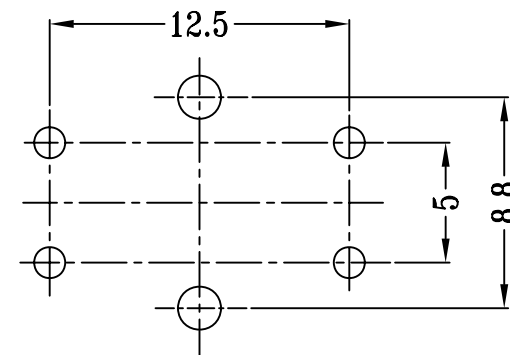
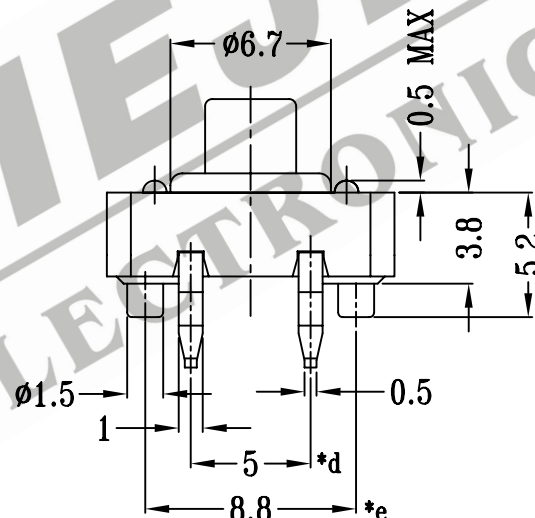
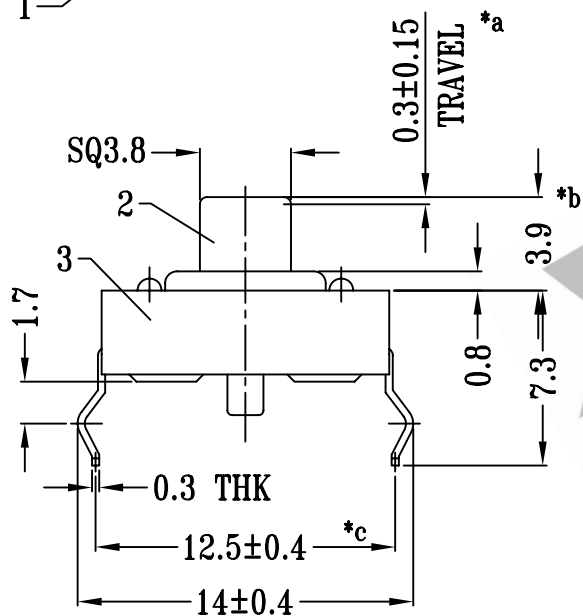

**P.C.B LAYOUT**

注:带"\*"表示关键尺寸(5个)

NO.	PARTS	MATERIALS	Q'TY	FINISH	TOLERANCE UNLESS SPECIFIED	SHENZHEN XIEJIA ELECTRONICS CO.,LTD.				
8					WITHIN: 1.5±0.1mm OVER : 1.5±0.2mm	ISSUE	DATE	DESCRIPTIONS OF REVISION		APPD.
7										
6										
5										
4	CONTACT	PBS	1	Ag CLAD	TITLE : TACT SWITCH	UNIT : mm	DRWG NO.: XJ-DR-TC12EC-00			
3	CASE	NYLON+F.G/BRASS STRIP	1	BLACK/Ag PLATED						
2	KNOB	POM	1	BLACK	MODEL: TC-12EC	SCALE: 3:1	DWN.	ZHOUYU	2005-9-22	
1	COVER	PE-T	1	CLEAR			CHK'D	FANGYING	2005-9-22	
					ALL MATERIALS MUST BE COMPLIANT TO ROHS	APPD.	KANGXINAN	2005-9-22		